

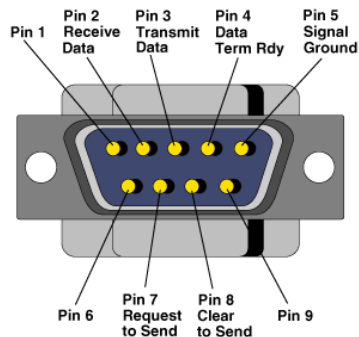

Com-port keyer

Ready to use (PSK) interfaces can be ordered at the web shop www.sec-digital.de.

The images below shows how a simple interface between the rig and the PC can be made. A 9-pin COM connector has its DTR at Pin 4 and pin 5 is GND.



Components

These are the components used for the circuit:

R3 = 330 Ohm (orange, orange, brown)

R4 = 12 Ohm (brown, red, black)

R5 = 1 kOhm (brown, black, red)

R6 = 1,5 kOhm (brown, green, red)

C2 = 4,7 uF

D3 = 1n4148

T1 = BC549

Connectors

2 stereo plugs for the connection to the sound card.

1 sub-d connector for the com-port.

Dependant on the brand of the PMR, 1 or 2 connectors for the PMR.

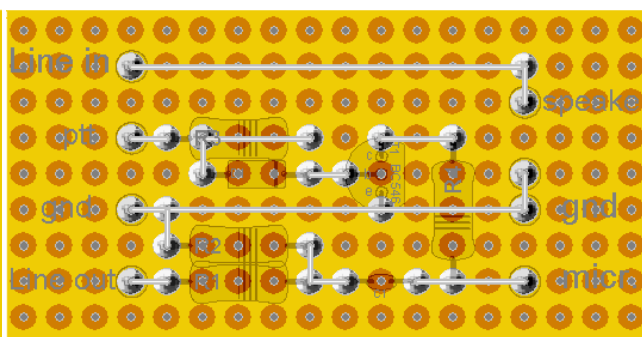
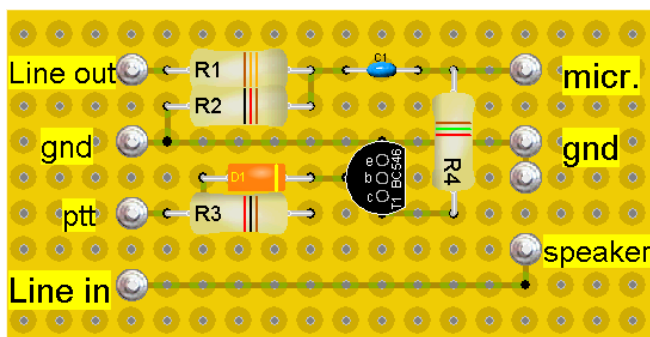
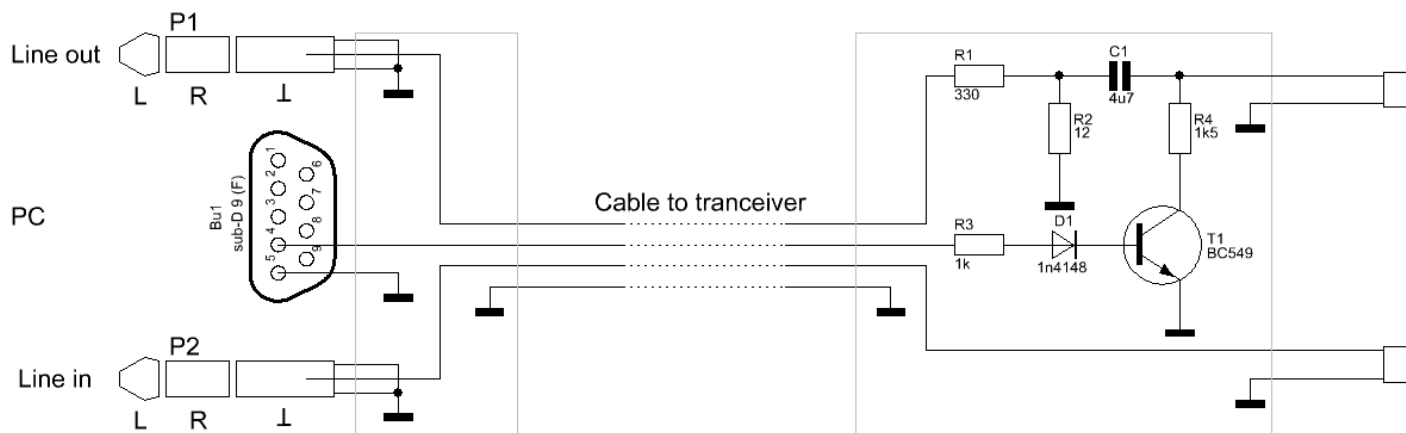

Settings in FRN Client

The image below shows how to setup FRN for the com port keyer. Do not forget to disable the VOX in the PMR. Click on *Settings* -> *Interface* to open the *Interface*-dialog.

